

# TCW Lube Free Wash Down Air Powered Hoists

## Clean Environment Solutions

Harrington's TCW Series Lube Free Wash Down Air Hoists are designed for use in humid, limited corrosive and outdoor environments or where equipment must be washed off on a regular basis. These industrial, severe duty rated hoists are perfect for food processing, food handling and pharmaceutical industries.



MODEL: TCW1000P2

## Clean Features

- Unpainted compact & lightweight cast aluminum body
- Stainless steel and bright chromate coated components
- Gear box and chain lubricants comply with FDA standards
- Lube free operation keeps surrounding area free of oil mist
- Zinc-plated corrosion resistant load hook

## Premium Standard Features

- Unlimited duty cycle for continuous operation
- Spring-loaded multi-vane motor design permits fine feathering control
- Extremely fast lifting for applications where speed is critical
- Low noise levels add to operator comfort
- Nickel-plated load chain is resistant to corrosion, abrasion and wear
- Easy access external speed adjustment
- Adjustable lifting / lowering speeds increase production capabilities
- Heavy-duty disc motor brake system for reliable load support

## Specifications

- **Capacity Range** - 1/2 & 1 Ton
- **Standard Lift** - 10' (longer lifts available)
- **Air Supply Requirement** - 60 – 90 psi
- **Air Filtration** - Maximum 5 micron air filter or finer required
- **Air Inlet Port** - 1/2" NPT
- **Air Supply Hose Minimum Size** - 1/2"
- **Temperature Range** - +14° – 140°F
- **Chain Containers** – Optional (Canvas or Steel)
- **Stainless Steel Load Chain** – Optional

*Ask your local sales representative or call our Customer Service staff for friendly and expert advice on models and options.*

## PENDANT MODEL—SPECIFICATIONS

Cap. (Tons)	Product Code	Standard Lift (ft)	Push Button Hose L (ft)	Up/Down Speeds (ft/min @ 90 psi)		Up/Down Air Consumption Rates (cubic ft/min @ 90 psi)		Load Chain Diameter (mm) x Chain Fall Lines	Net Weight (lbs)	Weight for Additional One Foot of Lift (lbs)
				No Load	Full Load	No Load	Full Load			
1/2	TCW500P	10	8.2	79 / 53	43 / 79	64 / 57	57 / 64	6.3 x 1	46	0.6
1	TCW1000P2			39 / 26	21 / 39	64 / 57	57 / 64	6.3 x 2	60	1.2

## PENDANT MODEL—DIMENSIONS

Cap. (Tons)	Product Code	Headroom C (in)	a (in)	b (in)	d (in)	e (in)	g (in)	h (in)	i (in)	j (in)
1/2	TCW500P	16.3	14.4	8.7	6.4	8.0	1.0	5.3	3.3	1.0
1	TCW1000P2	18.0	14.4	9.0	6.4	8.0	1.1	6.3	2.7	1.9

## CORD MODEL—SPECIFICATIONS

Cap. (Tons)	Product Code	Standard Lift (ft)	Cord L (ft)	Up/Down Speeds (ft/min @ 90 psi)		Up/Down Air Consumption Rates (cubic ft/min @ 90 psi)		Load Chain Diameter (mm) x Chain Fall Lines	Net Weight (lbs)	Weight for Additional One Foot of Lift (lbs)
				No Load	Full Load	No Load	Full Load			
1/2	TCW500C	10	7.3	79 / 53	43 / 79	64 / 57	57 / 64	6.3 x 1	44	0.6
1	TCW1000C2			39 / 26	21 / 39	64 / 57	57 / 64	6.3 x 2	58	1.2

## CORD MODEL—DIMENSIONS

Cap. (Tons)	Product Code	Headroom C (in)	a (in)	b (in)	d (in)	e (in)	g (in)	h (in)	i (in)	j (in)
1/2	TCW500C	16.3	14.4	8.7	6.4	8.0	1.0	5.3	3.3	1.0
1	TCW1000C2	18.0	14.4	9.0	6.4	8.0	1.1	6.3	2.7	1.9

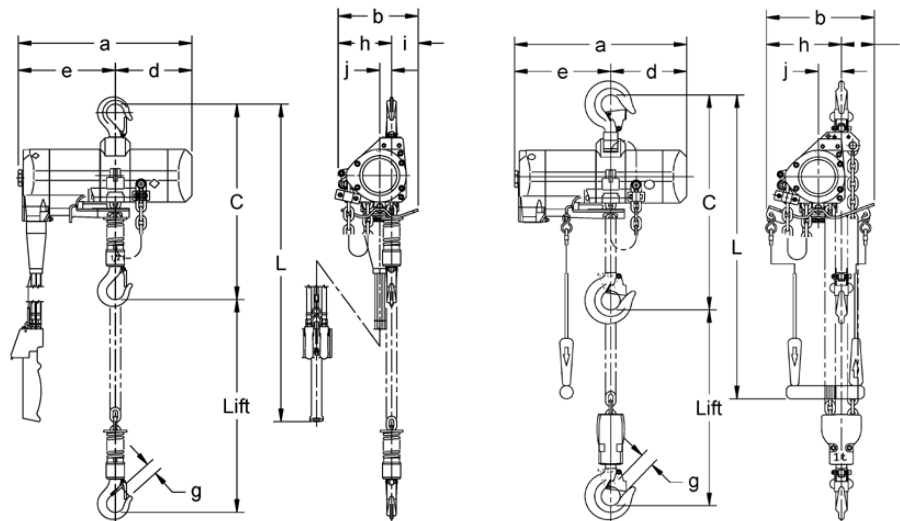

TCW500P

TCW1000C2

Harrington Hoists, Inc.  
401 West End Avenue  
Manheim, PA 17545



Toll Free: 800-233-3010  
Phone: 717-665-2000  
Fax: 717-665-2861

[www.harringtonhoists.com](http://www.harringtonhoists.com)