



Acco[®] Acco Material
Handling Solutions



WRIGHT[®]
PRODUCTS

ABOUT US

Since 1904, ACCO has been the premier manufacturer of material handling products including overhead cranes, hoists and warehouse/distribution carts and trailers. At ACCO our mission is to deliver **innovative** specialty material handling solutions in **collaboration** with our customers to **expand** our positive impact on the industrial world.

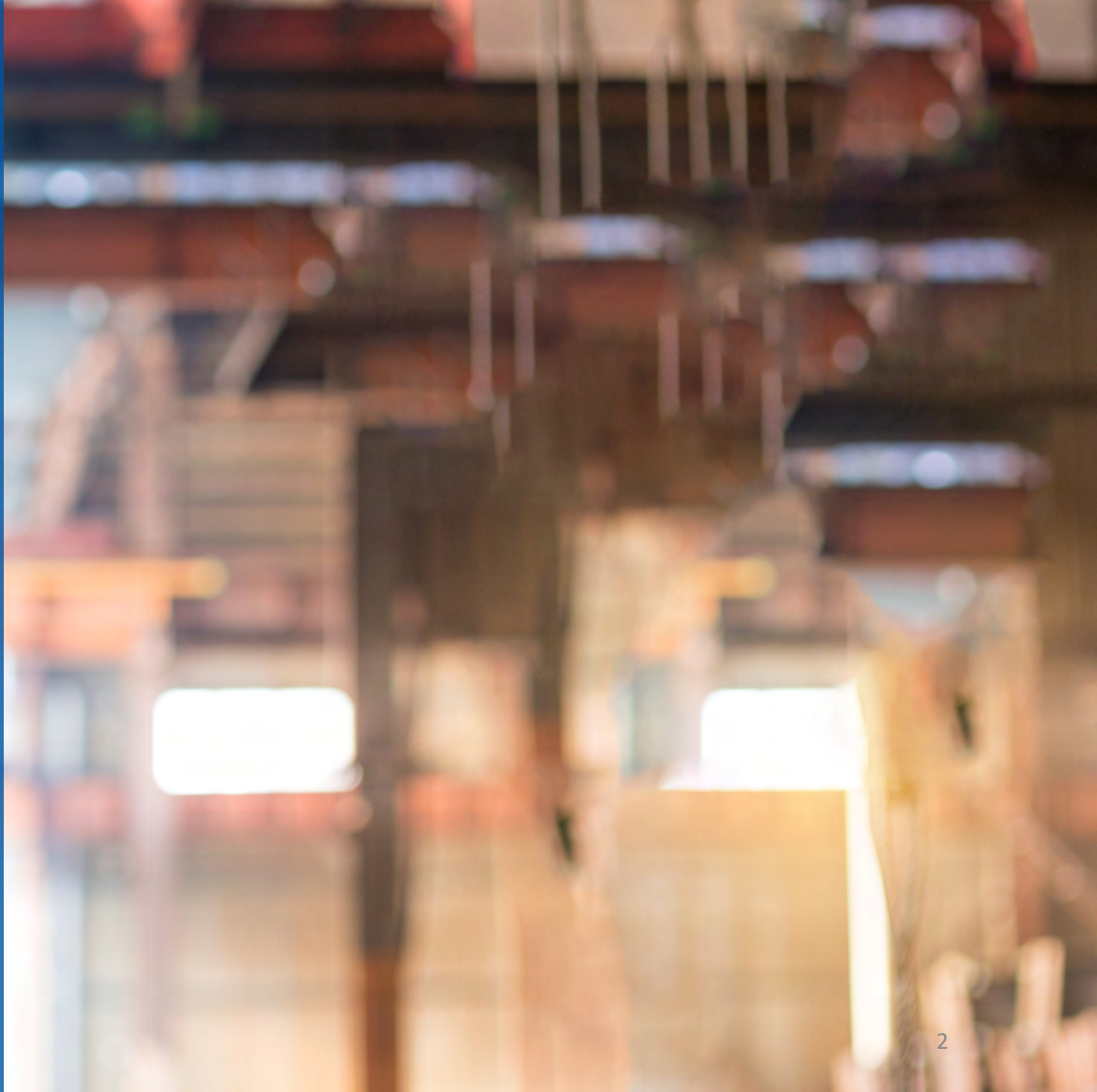

WRIGHT® PRODUCTS

Since its inception in the 1920's, the **Wright** brand has been synonymous with quality, performance and durability! Today, Acco's complete line of electric wire rope and electric chain hoists offer advanced designs and the most current duty cycle and safety requirements that meet industry standards.



Electric Chain Hoist

Accolift CLH



Electric Chain Hoist

Accolift



Wire Rope Hoist

Speedway



Wire Rope Hoist

Work-Rated

WRIGHT® WIRE ROPE HOISTS



WRIGHT[®] WIRE ROPE HOISTS

Duty Class	Typical Areas of Application
H1	Powerhouse and utilities, infrequent handling. Hoists are primarily to install and service heavy equipment, where loads frequently approach rated load, and where the hoist is idle for 1 to 6 month periods between periods of operation.
H2	Light machine shop, fabricating service, and maintenance. Loads and utilization randomly distributed. Rated loads infrequently handled. Total running time not over 12.5% of the work period.
H3	General machine shop, fabricating, assembly, storage, and warehousing. Loads and utilization randomly distributed. Total running time not over 25% of the work period.
H4	High volume handling of heavy loads, frequently near rated load in steel warehousing, machine and fabricating shops, mills, and foundries, with total running time not over 50% of the work period. Manual or automatic cycling operations of lighter loads with rated loads infrequently handled such as in heat treating and plating operations, with total running time frequently 50% of the work period.
H5	Bulk handling of material in combination with buckets, magnets, or other heavy attachments. Equipment often cab operated. Duty cycles approaching continuous operation are frequently necessary. User must specify exact details of operation, including weight of attachments.

All New Century Hoists are H4 Duty



WRIGHT® WIRE ROPE HOISTS

Suspensions

- Standard Monorail (drum parallel to beam)
 - Motorized Trolley
 - Push/Pull Trolley
 - Hand Geared Trolley
 - Lug Mounted
- Cross Mounted/Low Headroom Monorail (drum perpendicular to beam)
 - Motorized Trolley
 - Push/Pull Trolley
 - Lug Mounted



Standard Monorail



Cross-Mounted/Low Headroom

WRIGHT®

WIRE ROPE HOISTS | SUSPENSIONS



Top Running Trolley

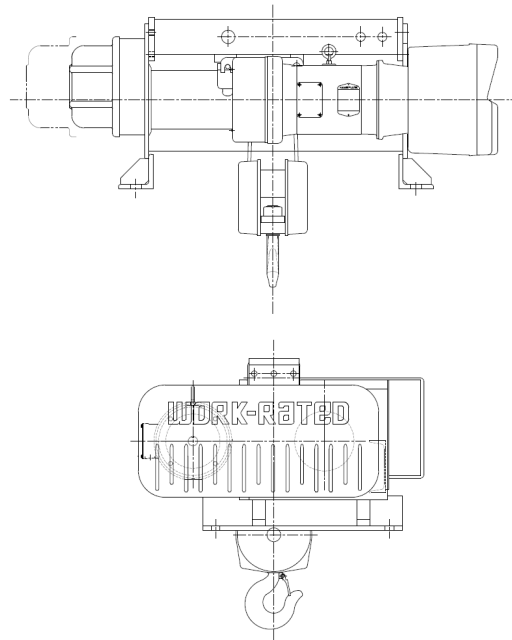

Deck Mounted

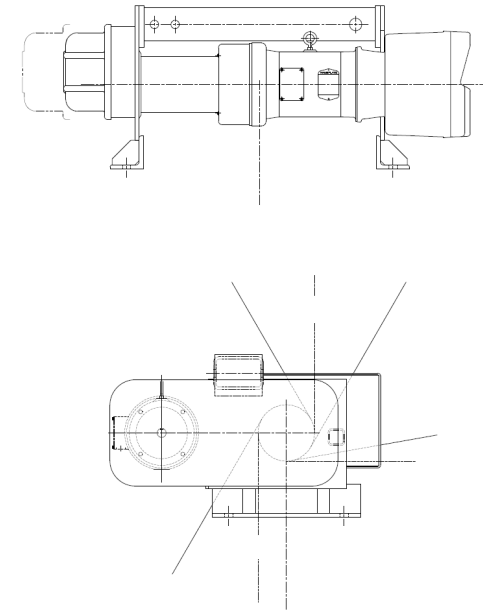

Winch

- Single Reeved

- Results in a lift that moves side-to-side as it lowers
- It can also rotate to varying degrees depending on drum length as the wire rope pays out

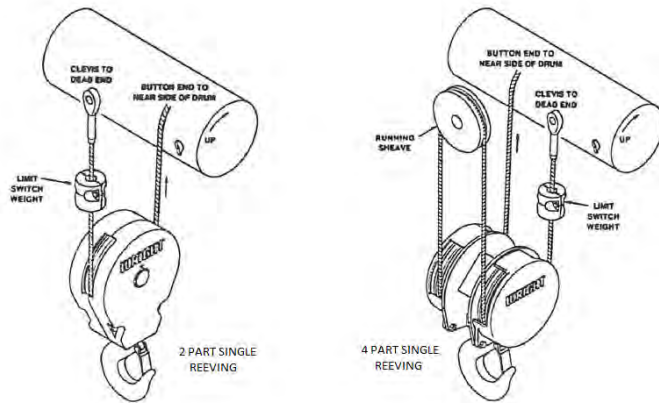

- Double Reeved

- Results in a lift that is truly vertical

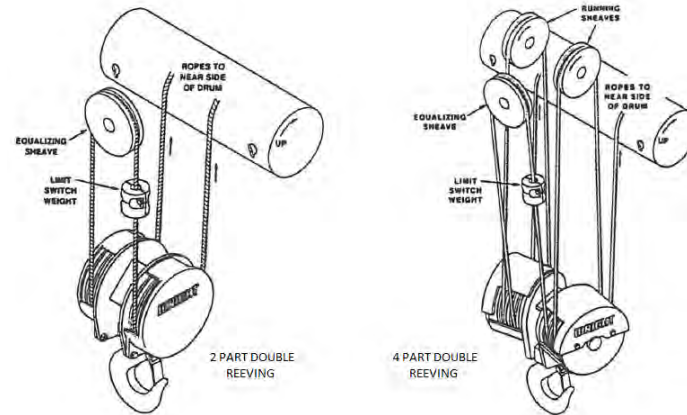

WRIGHT®

WIRE ROPE HOISTS | SPEEDWAY

SPEEDWAY® HOISTS

THE NEW CENTURY SERIES®

Capacities of 1 to 5 tons.

WRIGHT®

BASIC CONTROLS

Choose single or two speed. Magnetic reversing contactors, both mechanically and electrically interlocked. 115V control circuit. Meets NEC requirements. NEMA Type 3R enclosure. Lightweight, durable, and easily accessible.

MOTOR BRAKE

Proven in millions of hours of in-service operation, the original Wright A-C magnet-actuated disc brake delivers rapid stops with virtually no hook drift. Rated a minimum of 150% of full load motor torque.

MOTOR

The New Century Series utilizes a U.S. manufactured motor, 30-minute duty. Class F insulation. Standard single speed motor is provided for 200V, 230V/460V, or 575V 3 phase, 60 hertz power supplies. Motor thermostats are standard - providing both running and overcurrent protection.

DRUM

Has machined grooves and large flanges for smooth winding and extended rope life. At least two full turns of rope remain on the drum at the lowest hook position.

LIMIT SWITCH

A gravity type upper hook travel limit switch comes equipped with an automatic momentary lowering circuit.

LUBRICATION

Gears operate in the largest oil reservoir in the industry and are enclosed in a rugged fluted aluminum alloy housing to provide rapid heat dissipation. Oil sight gauge on the housing cover permits quick visual inspection.

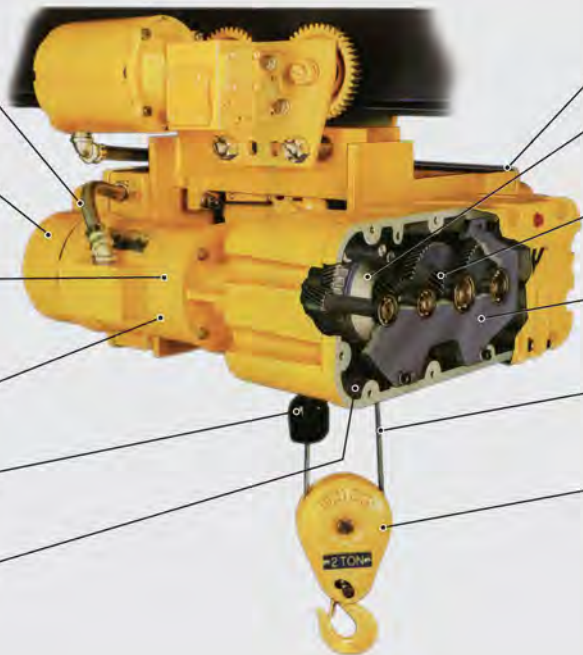

CONTROLS FOR OPTIONAL FEATURES

MECHANICAL LOAD BRAKE

Automatic Weston-Type multiple disc brake. It can hold a full capacity load independent of the motor brake and assures that the load does not accelerate while being lowered. Adjustment is not required.

GEAR TRAIN

Quiet, helical, and spur gearing. All gears are machine cut, case-hardened alloy steel with shock-resistant ductile cores. Designed to AGMA standards.

BEARINGS - SPIDER RETAINER

Precision heavy-duty ball bearings support all shafts. Bearings at outboard end of shafts are held in place by a heavy-duty Spider Retainer. This allows removal of Gear Housing Cover for inspection (after draining oil). All internal parts remain in place and can be operated for inspection.

WIRE ROPE

Pre-formed wire rope, of hoisting service construction, has swaged fittings on both ends for ease of replacement if necessary.

LOAD BLOCK - HOOK

Drop forged heat-treated steel hook swivels 360° on a shielded roller thrust bearing and comes equipped with a spring latch. Work can be performed on the load block without removing wire rope from drum. Sheaves are machined steel with machine finished grooves, to increase surface contact with hoisting rope.

OPTIONAL OVERLOAD CUTOFF

Protects load, hoist, and operator by interrupting raising circuit when hoist senses a damaging overload. When lifting circuit is interrupted, the lowering circuit remains intact to allow the load to be lowered and removed. After the overload is removed the lifting circuit is automatically restored. Overload Cutoff is accessible for field adjustments.

WRIGHT®

WIRE ROPE HOISTS | WORK-RATED

WORK-RATED® THE NEW CENTURY SERIES® HOISTS

Four frame sizes in capacities of 1 to 25 Ton

OVERLOAD CUTOFF

Protects load, hoist and operator by interrupting raising circuit when hoist senses a damaging overload. When lifting circuit is interrupted, the lowering circuit remains intact to allow the load to be lowered and removed. After the overload is removed, the lifting circuit is automatically restored. Overload cutoff is accessible for field adjustments.

BASIC CONTROLS

Choose single or two speed. Magnetic reversing contactors, both mechanically and electrically interlocked. 115V control circuit. Meets NEC requirements. NEMA Type 3R enclosure. Lightweight, durable, and easily accessible.

MOTOR BRAKE

Proven in millions of hours of in-service operation, the original Wright® rectified D-C magnet-actuated disc brake delivers rapid stops with virtually no hook drift. Rated a minimum of 150% of full load motor torque. Exclusive brake-sensing microswitch prevents motor from operating against engaged brake and when brake requires adjustment.

MOTOR

The New Century Series utilizes a U.S. manufactured motor, 30-minute duty, Class F insulation. Standard single speed motor is provided for 208V, 230V/460V or 575V 3 phase, 60 hertz power supplies. Motor thermostats are standard, providing both running and overcurrent protection.

DRUM

Machined grooves and large flanges for smooth winding and extended rope life. At least two full turns of rope remain on the drum at the lowest hook position.

LIMIT SWITCH

A gravity-type upper hook travel limit switch comes equipped with an automatic momentary lowering circuit.

LUBRICATION

Gears operate in the largest oil reservoir in the industry and are enclosed in a rugged, fluted aluminum alloy housing. The oil bath and housing combined provide rapid heat dissipation, an important aspect of achieving the high volume hoist duty of an H4 classification. Oil sight gauge on the housing cover permits quick visual inspection.

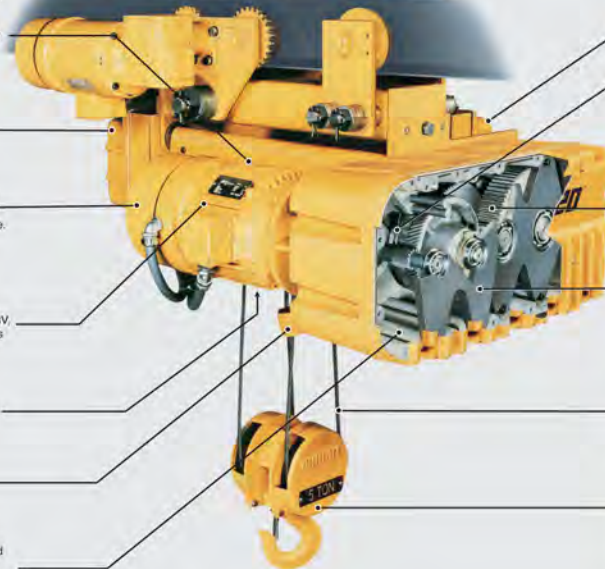

CONTROLS FOR OPTIONAL FEATURES

MECHANICAL LOAD BRAKE

Automatic Weston-Type multiple disc brake, carried forward from the original Work-Rated® design. It can hold a full capacity load independent of the motor brake and assures that the load does not accelerate while being lowered. Adjustment is not required.

GEAR TRAIN

Quiet, helical and spur gearing. All gears are machine cut, case hardened alloy steel with shock-resistant ductile cores. Designed to AGMA standards.

BEARINGS - SPIDER RETAINERS

Precision heavy-duty ball bearings support all shafts. Bearings at outboard end of shafts are held in place by heavy-duty spider retainers. This allows removal of gear housing cover for inspection (after draining oil). All internal parts remain in place and can be operated for inspection.

WIRE ROPE

Pre-formed wire rope, of hoisting service construction, made of extra improved plow steel (XIP) with an independent wire rope center. Has swaged fittings on both ends for ease of replacement if necessary.

LOAD BLOCK - HOOK

Drop forged heat-treated steel hook swivels 360° on a shielded roller thrust bearing and comes equipped with a spring latch. Work can be performed on the load block without removing wire rope from drum. Sheaves are machined steel with machine finished grooves to increase surface contact with hoisting rope.

WRIGHT®

SPEEDWAY & WORK-RATED SIMILARITIES

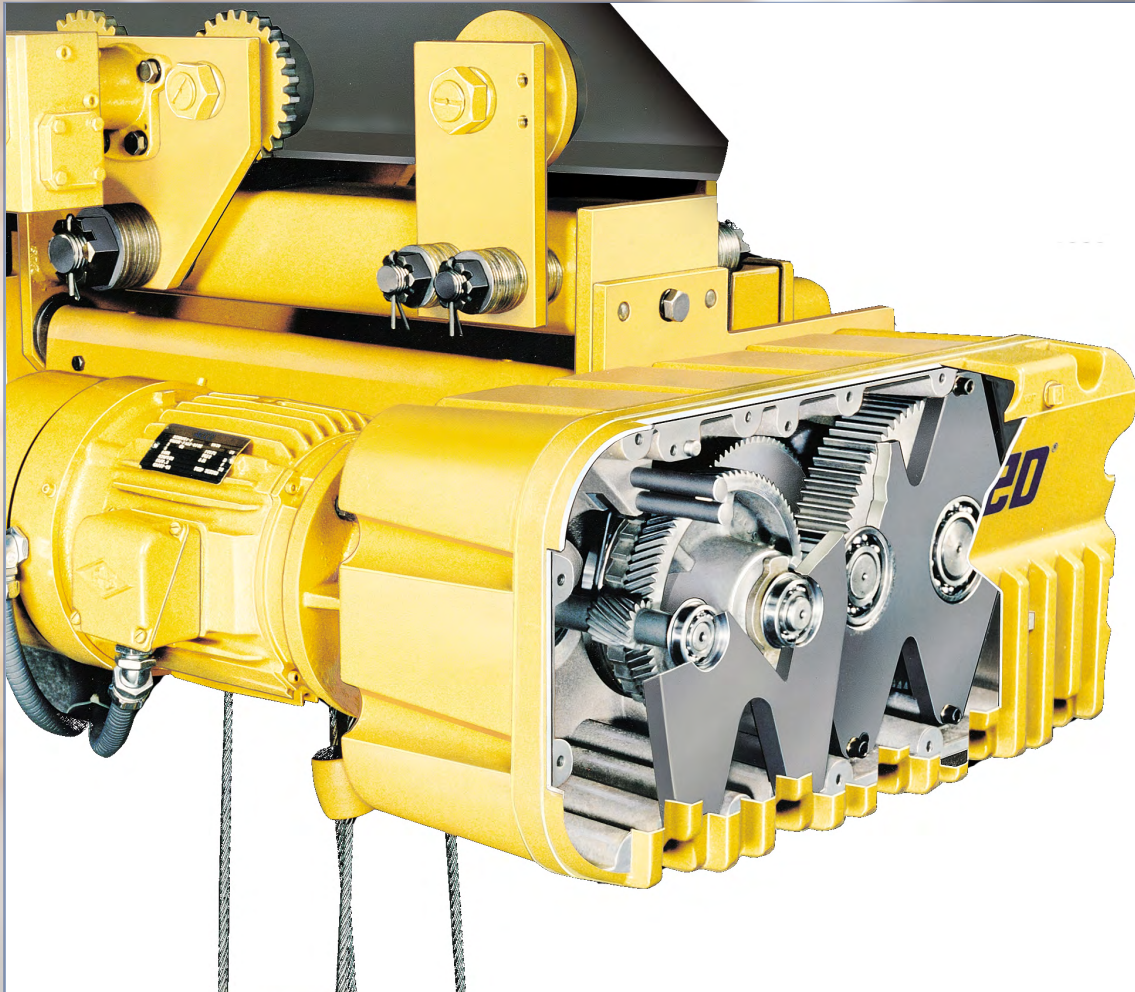

- Hoist Motors

- Standard motors are 1800 RPM
- Include Motor Thermostats
- Standard base motor is single speed, NEMA Design "D" (higher starting torque)
 - NEMA Design "D" motors **CAN** be used with inverters

- Gear Boxes

- Combination of spur and helical gears
- Mechanical load brake is standard
 - Weston style with ratchet and pawl
- Splash lubrication
- Oil site glass
- Standard oil is AGMA 6EP
 - EP additive required for our load brake

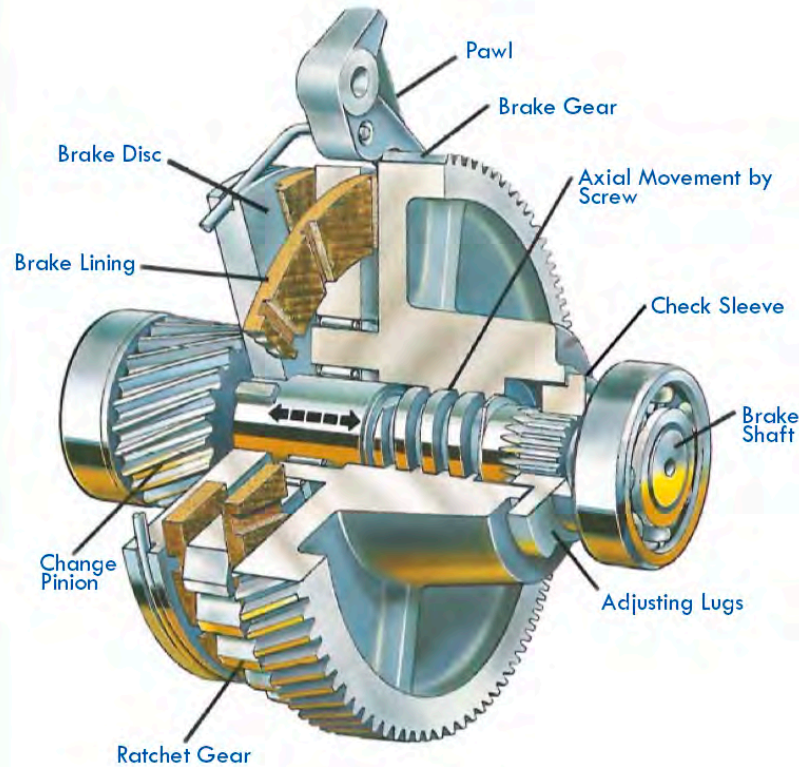

Mechanical Load Brake

Part of the gear train of the hoist, the load brake serves as a back-up to the electric motor brake. It automatically slows and controls lowering speed.

A Weston type load brake uses a brake gear with an internal helical thread which mates with a rotates n a threaded shaft. Brake linings bonded on both sides of a ratchet gear are engaged by the screw actuated axial movement of the brake gear along the threaded shaft...to the left toward the brake disc while raising the load and to the right away from the disc while lowering the load. If the load starts to accelerate during lowering, the brake gear moves again to the left slowing lowering speed and preventing the load overdriving the hoist motor.

WRIGHT®

SPEEDWAY & WORK-RATED SIMILARITIES

- Drums

- Single and double reeved
- Helical grooving
- Made of tube steel with welded flanges
- Wire rope drum dead end fits in to key slot with swaged “button” fitting(s)

- Wire Ropes

- Standard made of extra-improved plow steel (XIP)
- Independent wire rope center construction (IWRC)
- All have ID tag at drum dead end
 - Labeled “WRIGHT FACTORY AUTHORIZED PART” includes P/N, PO#, Tracking # and Acco Phone #



- Load Block

- All but the Series 31, 1 ton and 2PS have a welded steel frame
 - Series 31, 1 ton and 2PS have cast load block halves
- Running sheaves are on bearings (no bushings)
- All load blocks are shrouded
- Hooks are on thrust bearing for 360° rotation
- Standard hooks are single barbed, forged steel with spring latch
- Hooks are retained by slotted nut, locked in place by cotter pin

- Limit Switch

- Only limit switch provided across the line is a weighted upper gravity limit switch
 - Weight always used on the dead end of a wire rope

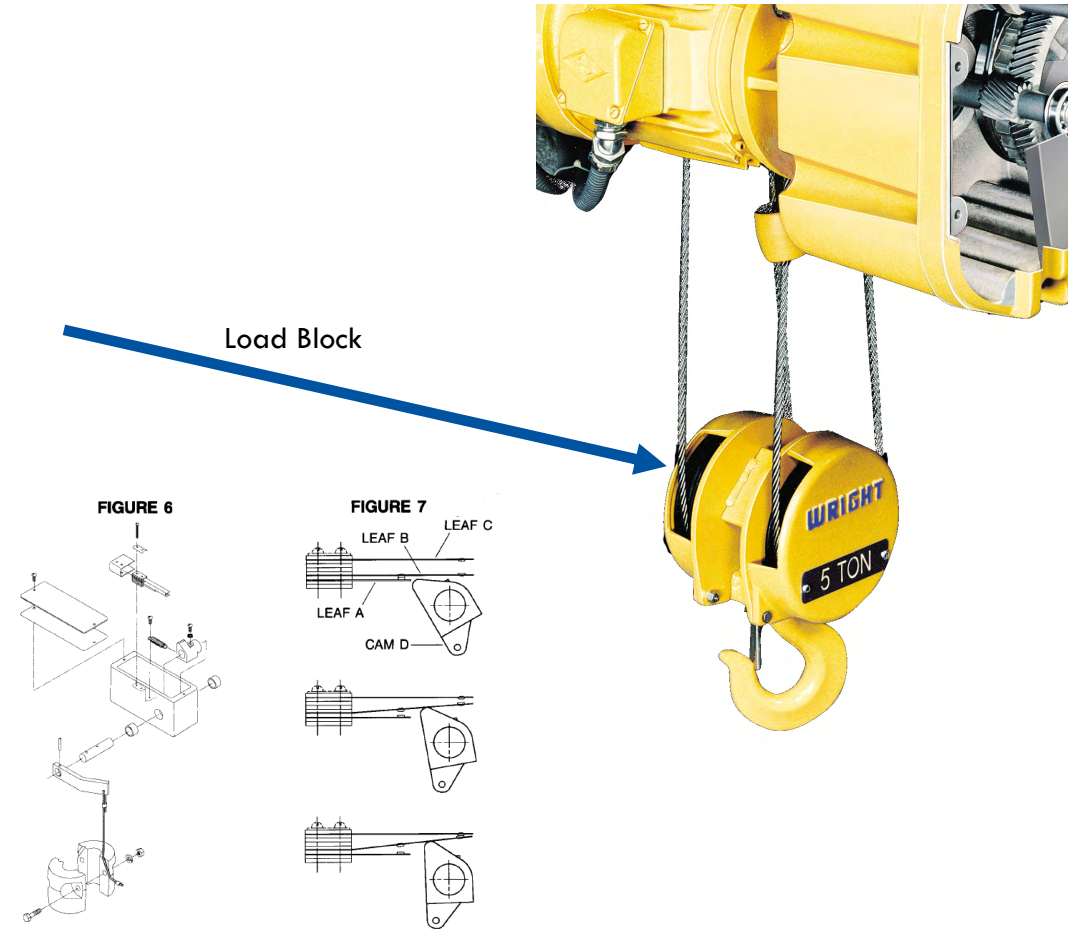

WRIGHT®

SPEEDWAY & WORK-RATED DIFFERENCES

- Hoist Frames

- Speedway frame is a 1-piece weldment
- Work-Rated is made of individual pieces that are pinned and bolted together



- Speedway Hoist Motor Brake

- A/C Brake with (1) brake coil
- Anywhere from (1) to (3) discs
- All brakes use the same springs

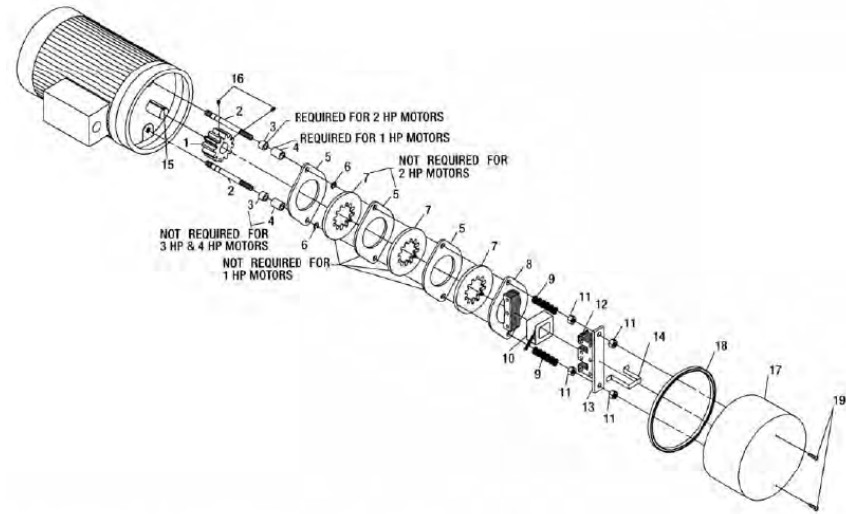

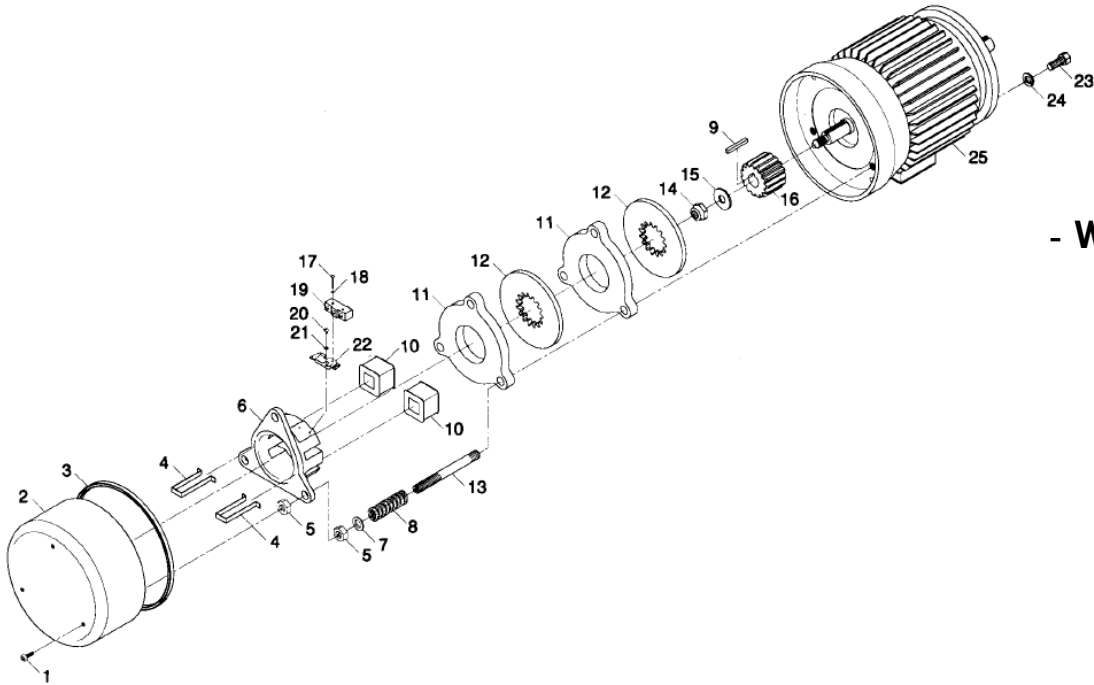

- **Work-Rated** Hoist Motor Brake

- D/C Brake with (2) to-up-to (4) brake coils
- All have (2) discs
- Different spring colors for different brake torques
- Includes brake switch to reduce voltage to coil
 - Extends brake coil life by cutting voltage to coils from 90 VDC to 45 VDC
 - Gives feedback to hoist controls that brake is released

- Speedway Mechanical Load Brake (4 Red.)

- Uses brake cams and slotted nut with cotter pin to adjust gap
- Brake gear is on a bronze bushing

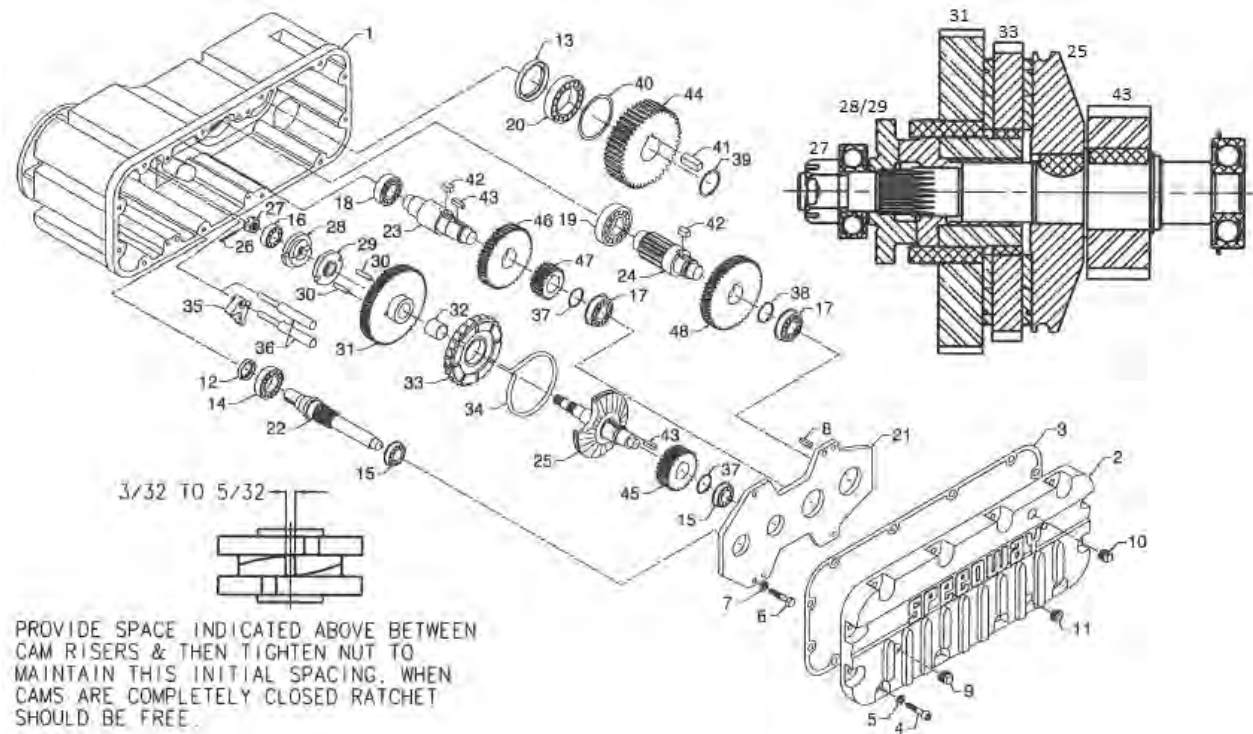

- **Work-Rated** Mechanical Load Brake

- Uses splined check sleeve for gap adjustment
- Brake gear is on needle bearings

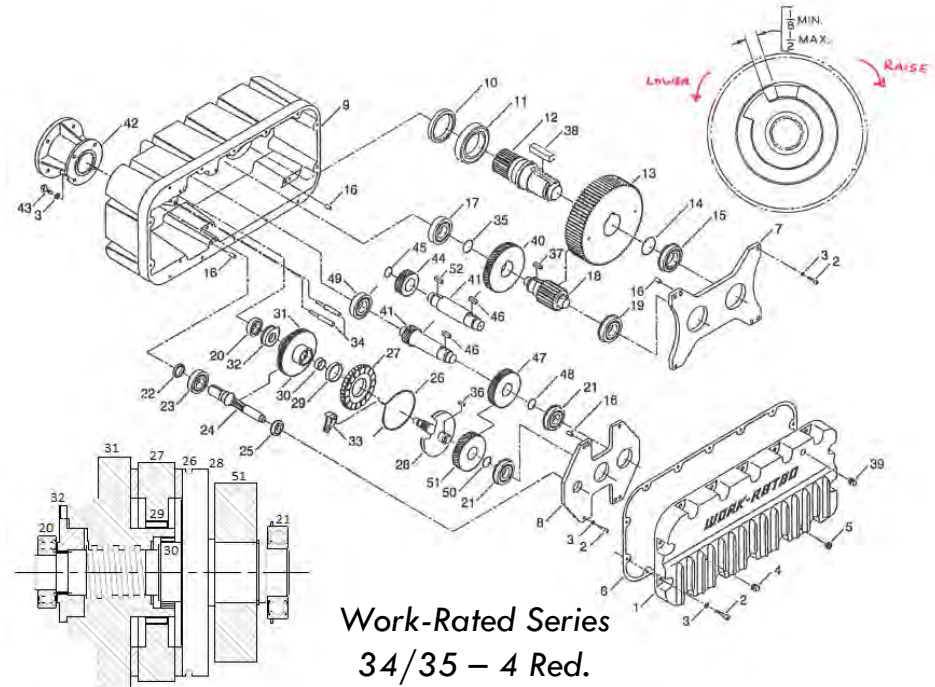
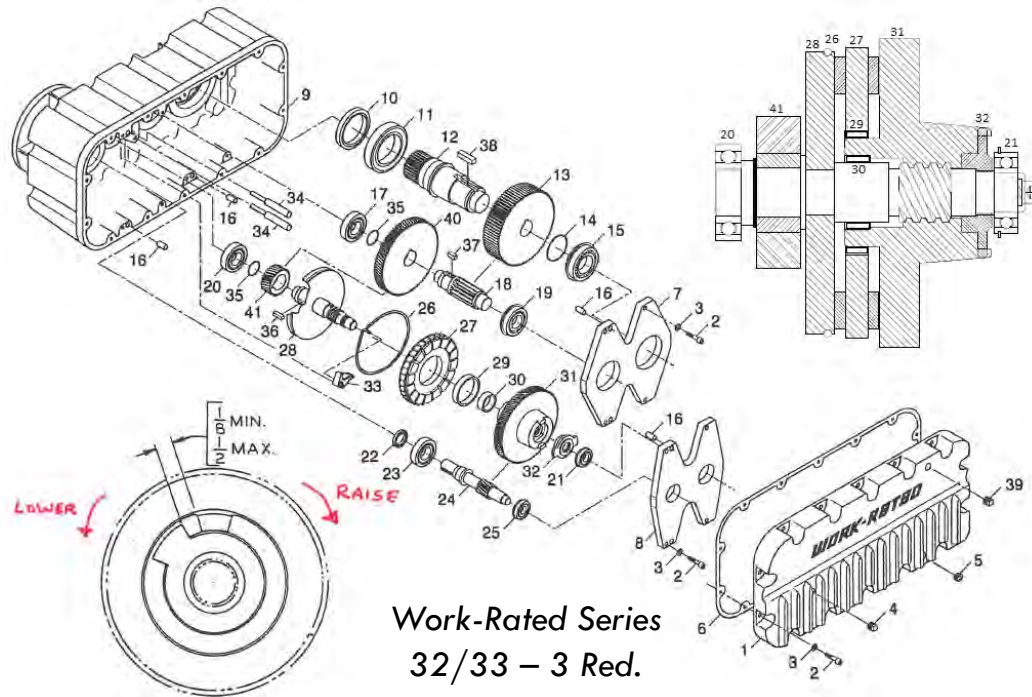

- Speedway Drums

- All of the same diameter
- All have 50% grooving
- Drum has end flange with integral male drive shaft
 - Shaft is keyed

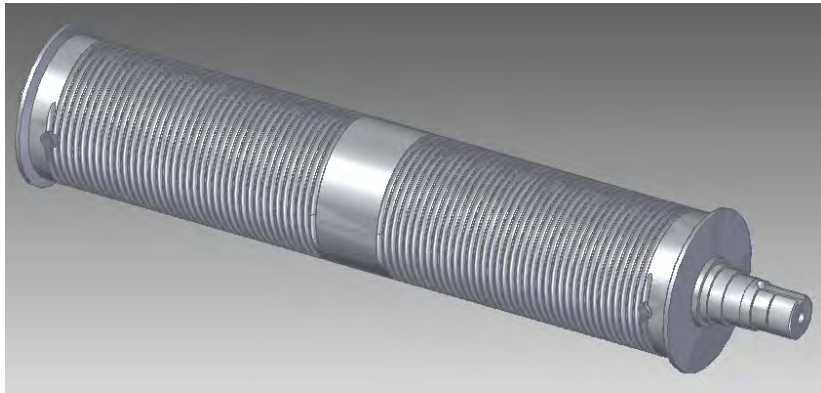

- Work-Rated Drums

- Diameter varies by series
- All have 35% grooving as standard
 - Can be special ordered with 50% grooving
- Drum has end flange with female spline

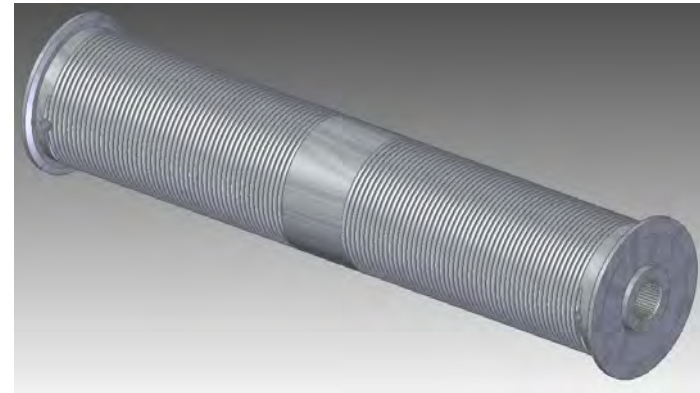

WRIGHT®

SPEEDWAY & WORK-RATED DIFFERENCES

- Speedway Wire Ropes

- (3) different standard diameters
 - 3/16", 1/4" and 5/16"
- Different rope classes
 - 3/16" is 6x19
 - Single reeved is 19x7
 - Double reeved is 6x31
 - 1/4"
 - Single reeved is 19x7
 - Double reeved is 6x31
 - 5/16" is 6x31

- Work-Rated Wire Ropes

- (5) different standard diameters
 - 3/8", 1/2", 9/16", 5/8" & 3/4"
- All are of class 6x37 (some manufacturer's refer to this as 6x36)



- Limit Switches

- Overload cutoff device
 - Optional on Speedway, Standard on Work-Rated

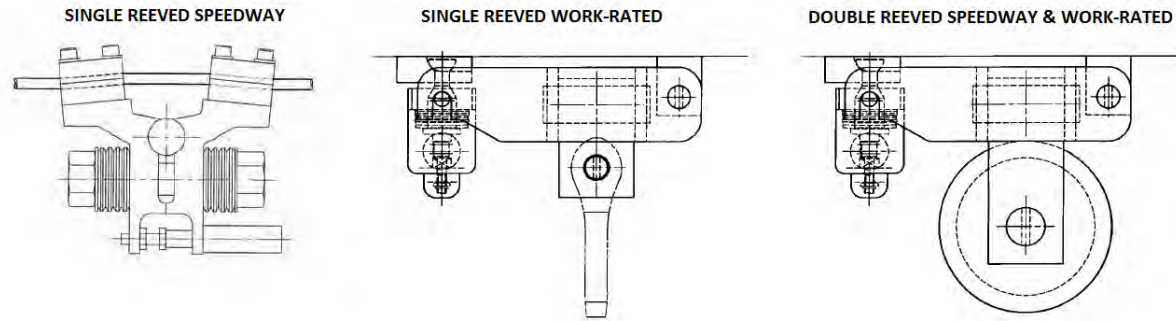

- U/L geared limit switch

- Optional (strongly recommended)
- Most are 2-circuit for max up and max down
 - A few are 4-circuit (GE style – rotary geared)
 - Mostly used for slow down logic or indicator lights
 - Note: Fairly inaccurate and not repeatable

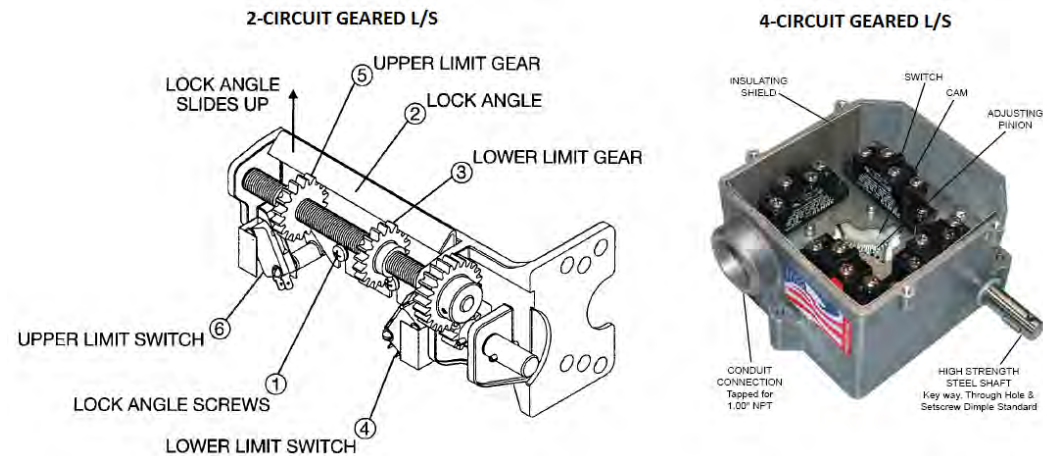



- Trolley Assemblies

- Offer plain (push/pull), hand geared and motorized
 - No hand geared cross-mounted or TRT's
- Most standard wheels are hardened to 375-425 BHN as standard
 - Exceptions: 1 & 2 ton Speedways are gray iron as standard
- Drop down lugs with rubber bumpers are available
 - Bent flat bar, welded to side plates
- Most models have swiveling trolleys available
 - Always requires dual drives, when motorized
 - Side guide rollers sometimes required
 - Depends on the radius and how far apart the wheels are
- Trolley disc brakes are optional
 - Right angle gear reducer acts as a braking means

2-Wheel & 4-Wheel Assemblies

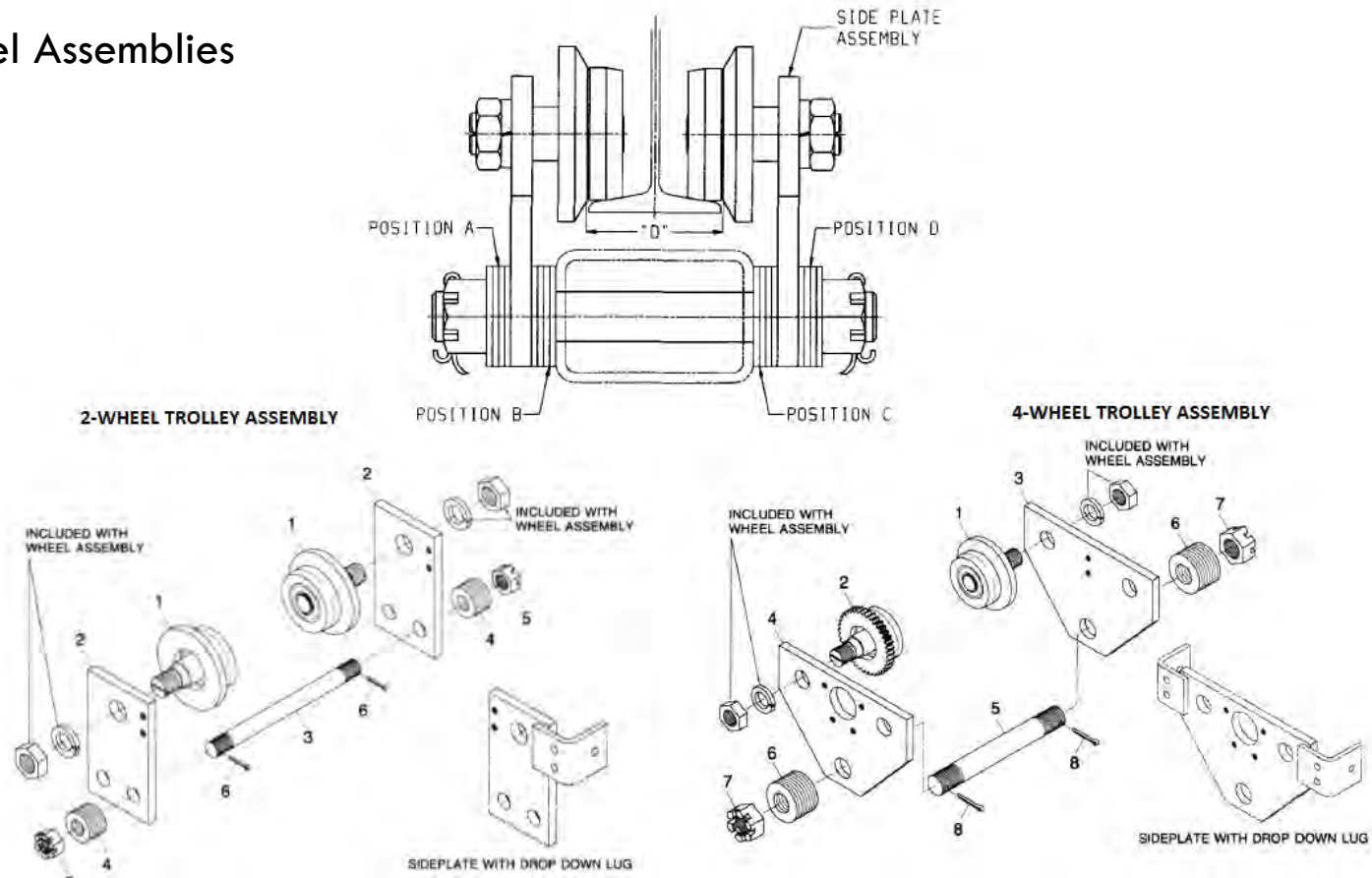

Hand-Geared Trolley Drive

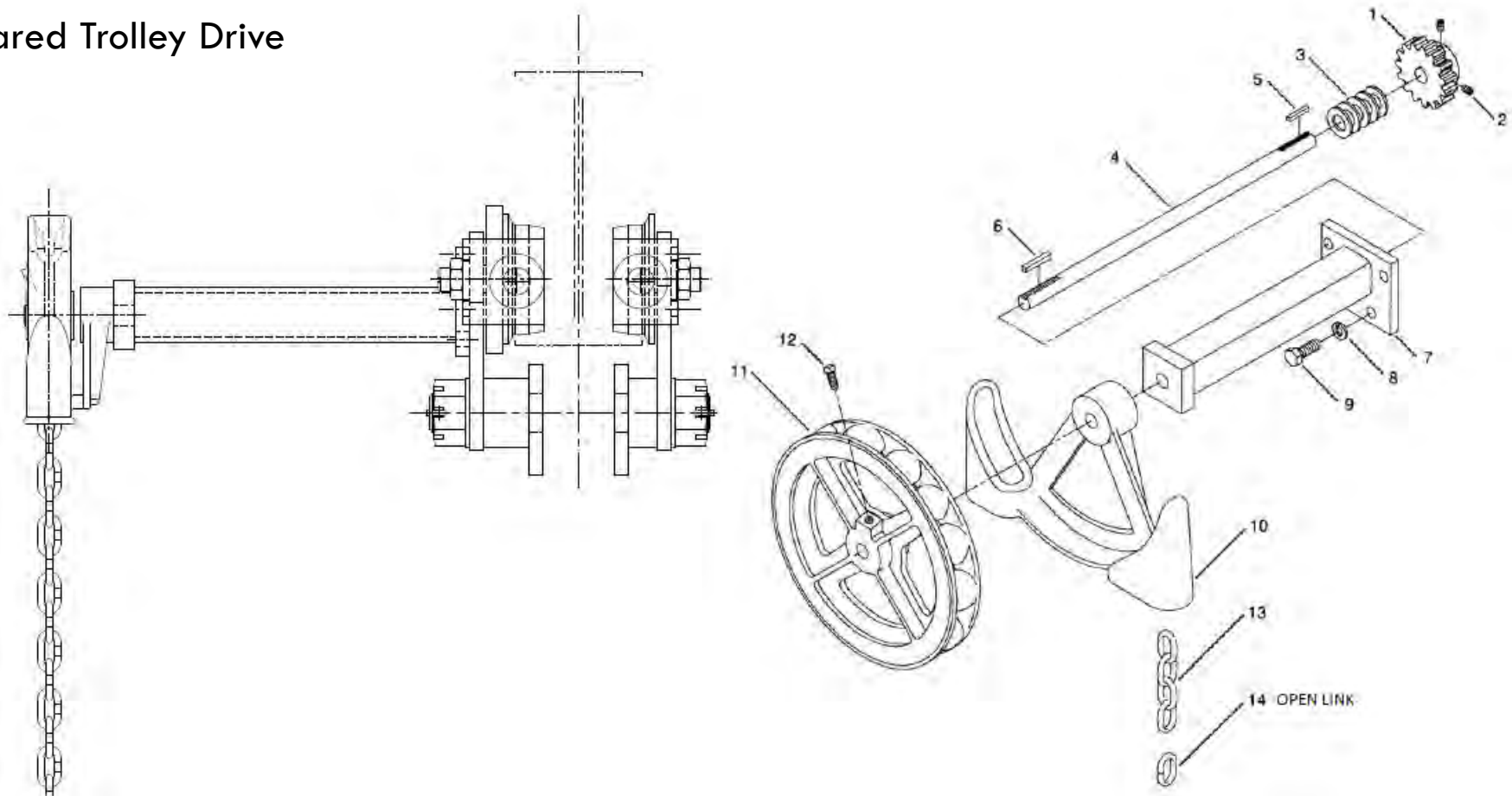

Motorized Trolley Drive

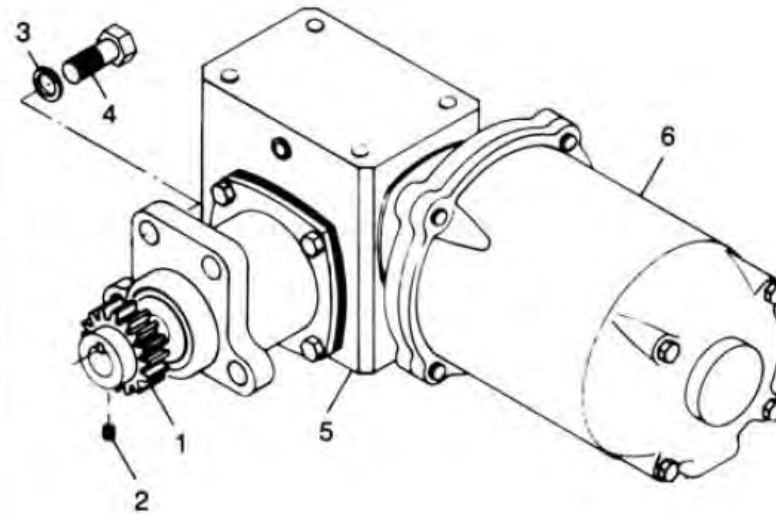
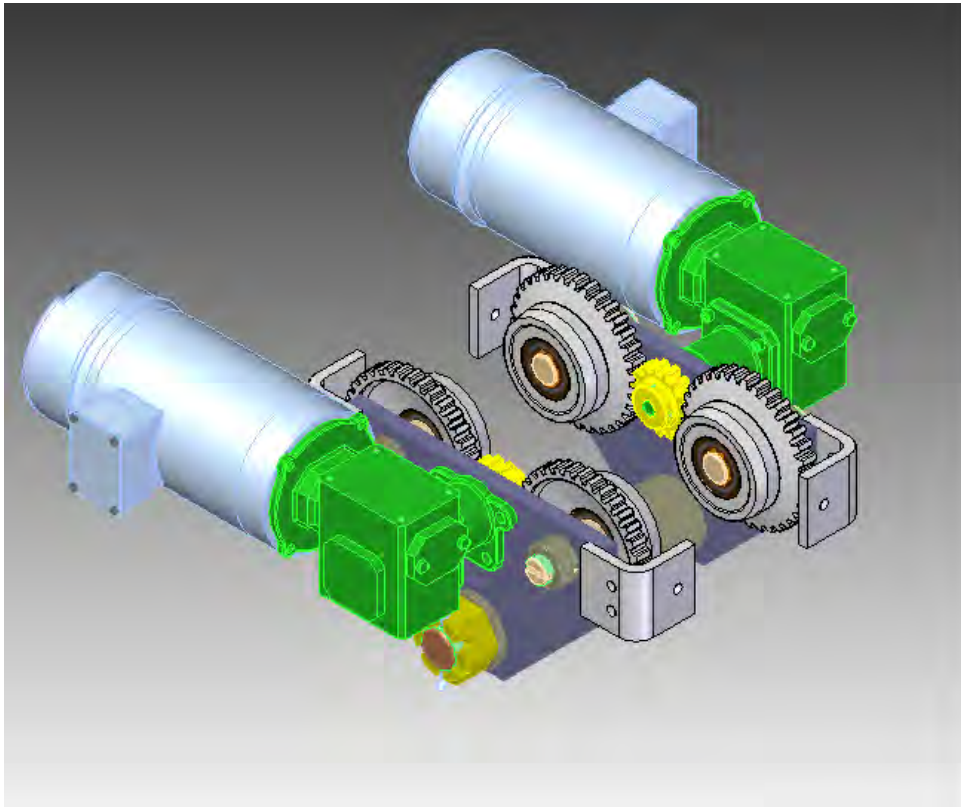

WRIGHT®

SPEEDWAY & WORK-RATED CROSS-MOUNTED/LOW HEADROOM HOISTS

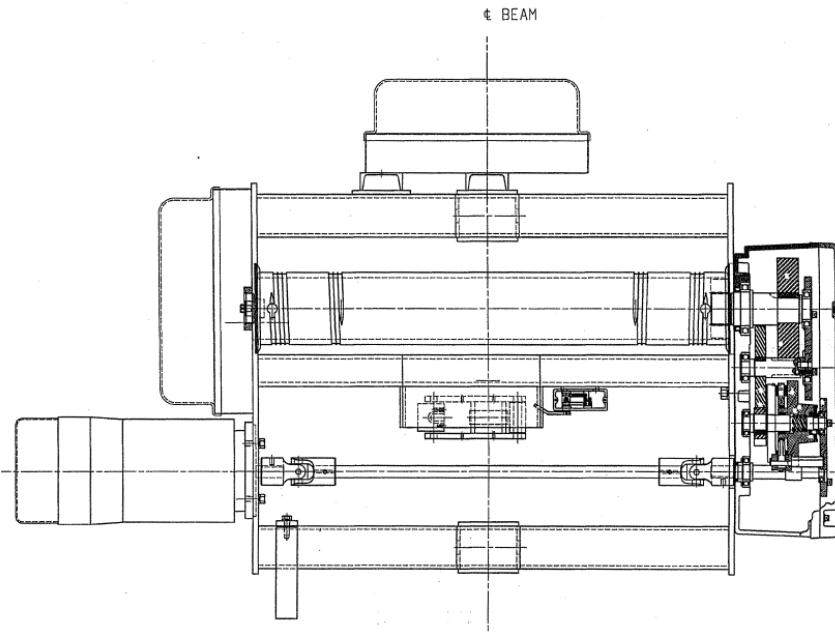

SERIES 32 2PD CROSS MOUNTED HOIST - DRUM NO. 6 - LESS TROLLEYS

- Cross-Mounted Hoists

- Drum is perpendicular to the monorail
- Offers better headroom and end approach
- Frame is a one-piece weldments
- Hoist motor and gearbox are on opposite sides of the hoist
 - Connected via crossover shaft and (2) universal joints
- Series 31 and 32 use a different gearbox housing and motor pinion shaft than on parallel mount
- Series 33 uses a different motor pinion shaft than on parallel mount (gearbox housing is the same)
- Not available on Series 34 and 35

Cross-Mounted Hoists vs Parallel Mounted Hoists

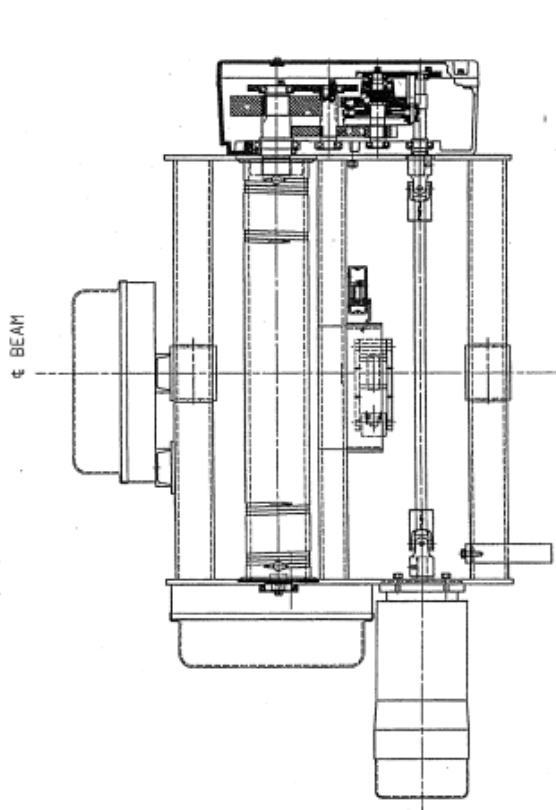

SERIES 32 2PD CROSS MOUNTED HOIST - DRUM NO. 6 - LESS TROLLEYS

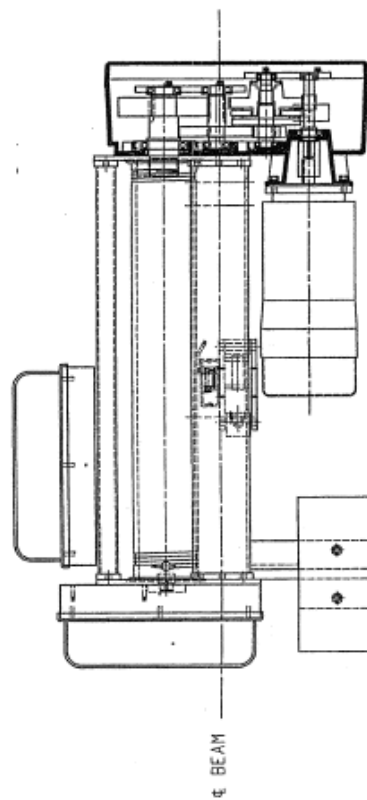

SERIES 32 2PD PARALLEL MOUNTED HOIST - DRUM NO. 6 - LESS TROLLEYS

Cross-Mounted U-Joints and Extension Shaft

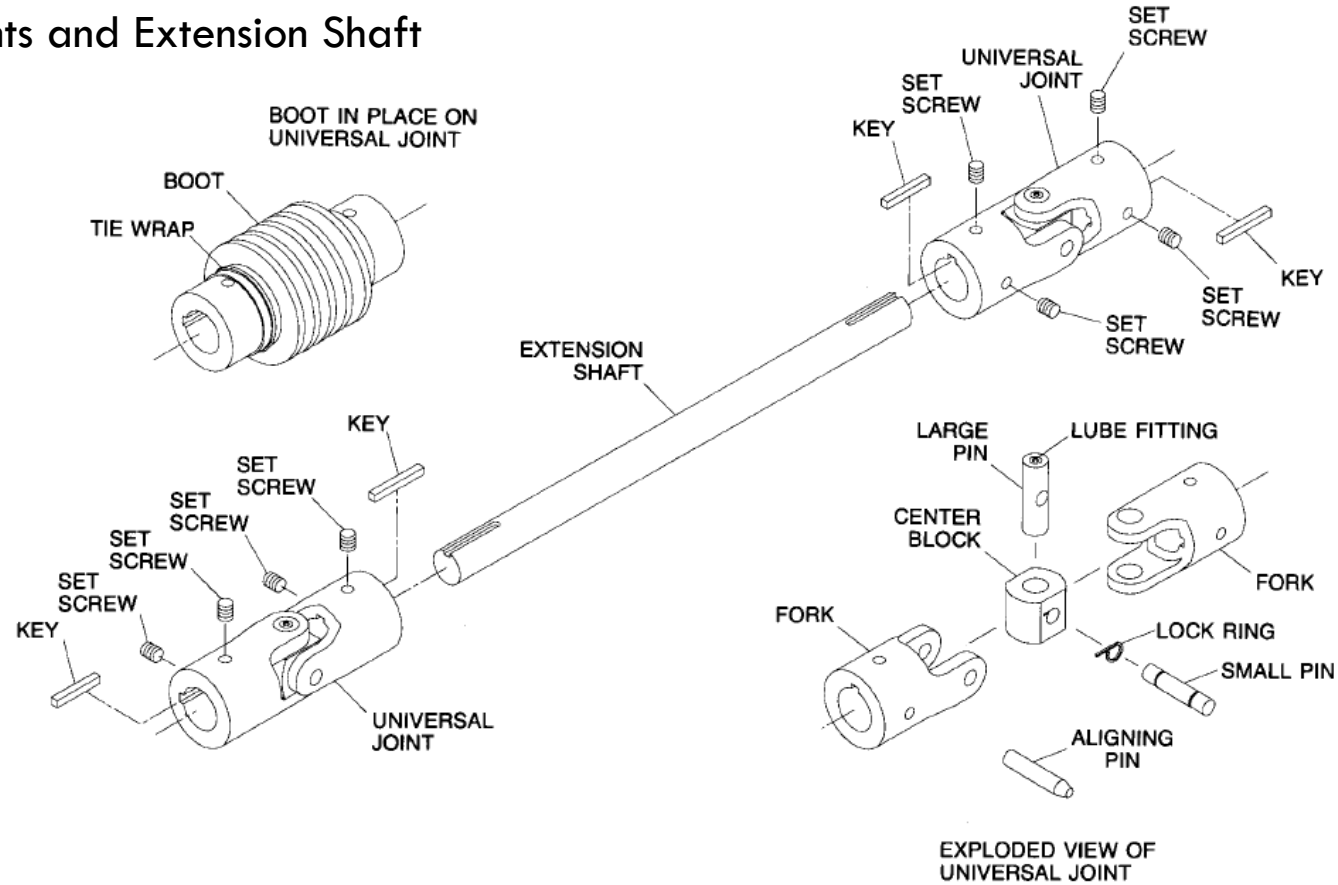

WHO WE ARE

SUB HEADING

Innovate. Collaborate. Expand.



Our Purpose

We help people move things. We increase productivity and safeguard lives in manufacturing, warehouse and plant operations by configuring specialized equipment that move materials seamlessly.

Our Vision

To redefine and lead the specialized material handling solutions market.

Our Mission I.C.E.

To deliver *innovative* specialty material handling solutions in *collaboration* with our customers to *expand* our positive impact on the industrial world.



ACCO VALUES AND CUSTOMER COMMITMENT

SUB HEADING



UNCOMPROMISING QUALITY

Our demonstrated product safety, quality and durability is best in market.



CUSTOMER FOCUS

We create customized solutions that solve the most complex customer challenges.



UNMATCHED RESPONSIVENESS

Our team of experts is the most responsive in the industry to personally address customer needs.



AFTERSALES EXCELLENCE

We provide the highest performing parts support in the industry.



UNPARALLED EXPERTISE

Our understanding and expertise in end use applications drives new business to our dealers.

ACCO's foundational DNA is at the core of its value proposition.

ACCO'S FOOTPRINT

SUB HEADING



ACCO Nutting - Custom Carts and Trailers (~30 EE's)

- 84,000 square feet of manufacturing and office space
- Manufacture and assembly of parts to make finished carts and trailers

Kresl Power – ACCO Partner and Master Parts Distributor

- Warehouse, pack, and ship OEM parts
- Warehouse, modify, pack, and ship stock wire rope hoists and imported ECH

ACCO Material Handling Solutions – HQ and Hoist Products (~90 EE's)

- 100,000 square feet of manufacturing space
- Design, machining, manufacture and assembly of parts to make finished wire rope hoists

ACCO Louden and Trambeam - Patented Track Cranes and Monorail (~30 EE's)

- 70,000 square feet of manufacturing space
- Manufacture and assembly of parts to make finished crane and monorail systems

